

Rocky, Zuma en Marshall willen graag een koekje. Verbind elke pup met 1 koekje.

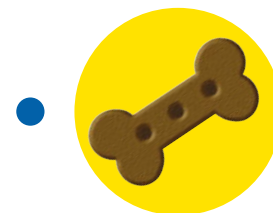

Doel: de 1-1-relatie leren toepassen.

Kijk goed naar de pups hieronder. Welke rij heeft de minste pups? Omcirkel die rij. Welke rij heeft de meeste pups? Kleur die pups in.

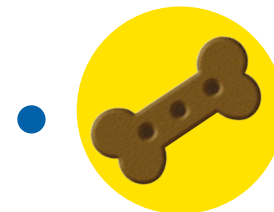
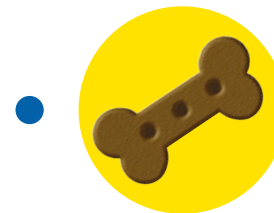
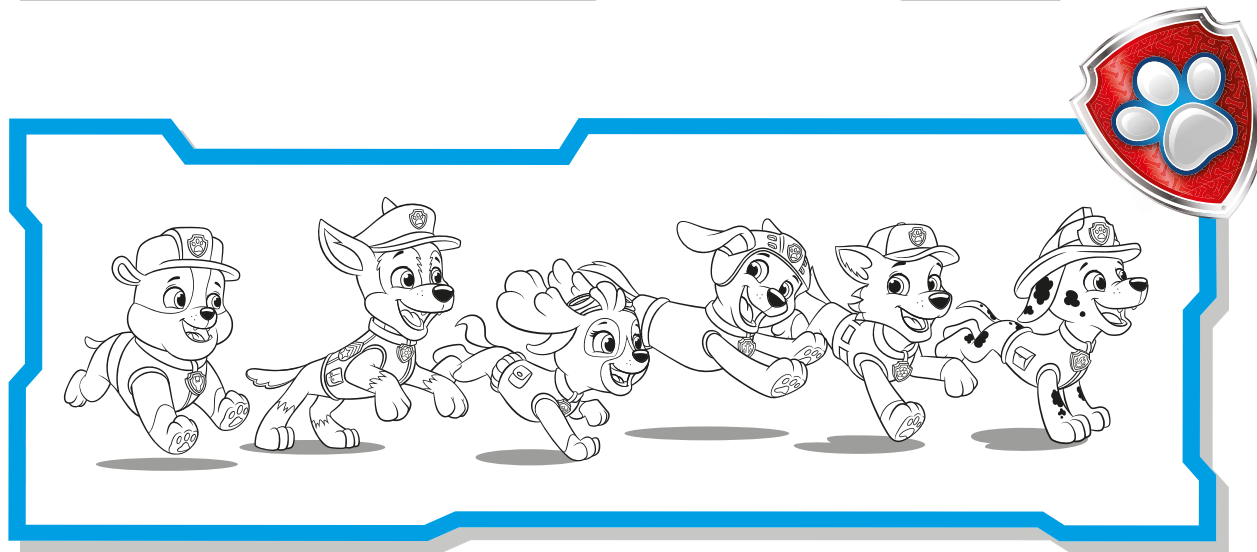
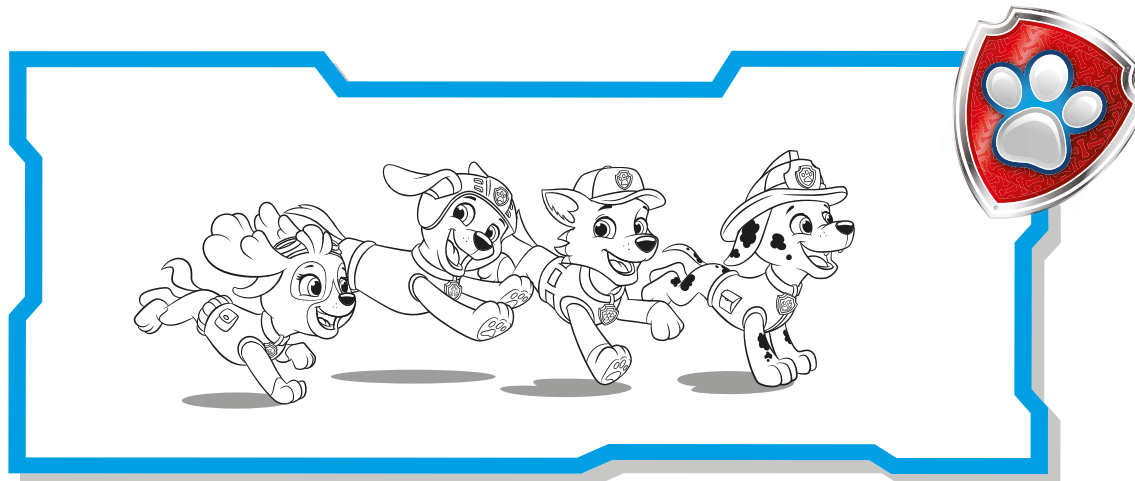

 Doel: de begrippen 'meeste' en 'minste' leren kennen.

Chase controleert de foto's van de pups. Op welke foto staat 1 puppy? En op welke 2? Verbind iedere foto met dezelfde hoeveelheid pootjes. **'Chase zit erbovenop!'**

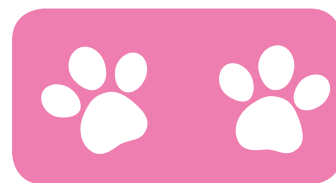
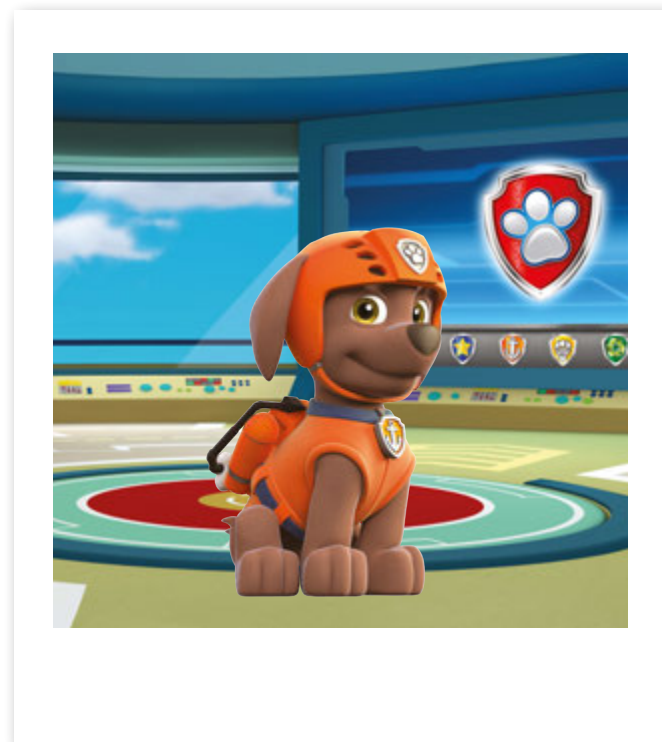
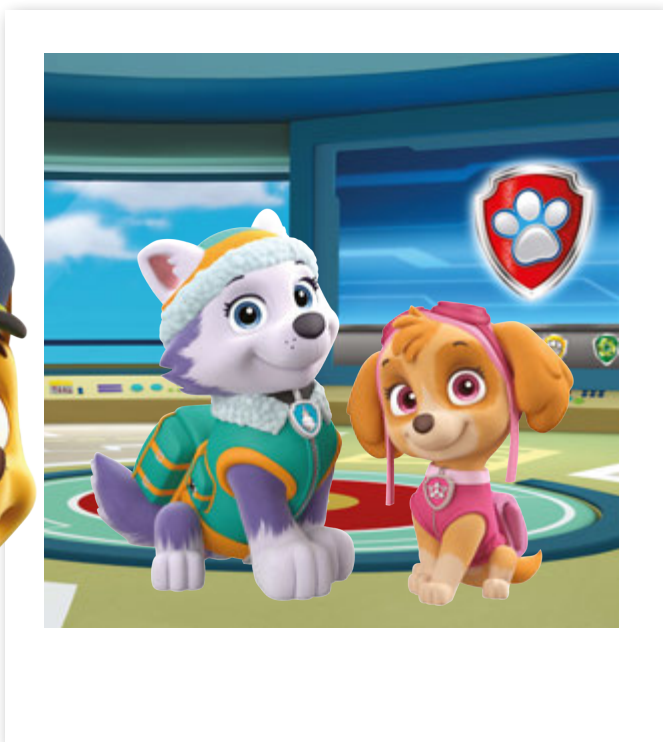

 Doel: leren tellen tot 2.

Everest moet tijdens een missie de berg af roetsjen in de sneeuw. Wat een mooie sneeuwvlokken!  
Tekenen om elke sneeuwvlok een kring. **'Sneeuw of kou, ik kom heel gauw!'**



Doel: de hoeveelheid 1 leren kennen.

Er is een nieuwe lading groenten en fruit bij meneer Porter geleverd. Zuma helpt uitladen.  
Kleur 3 tomaten, 1 tros bananen en 2 wortels.

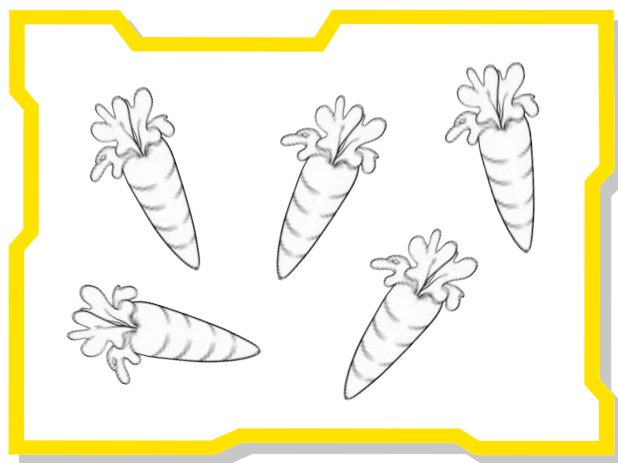
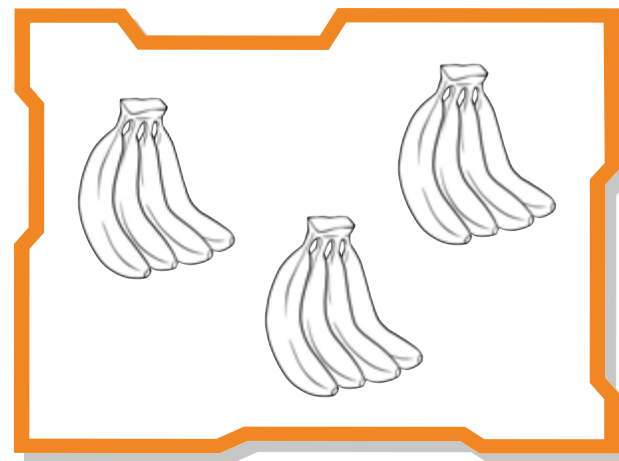
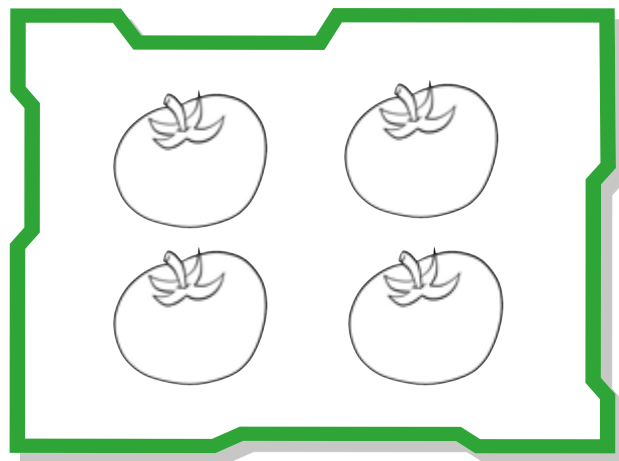

 Doel: leren tellen tot 3.

Kijk goed naar de kleurencode. Kleur alle helmen van Marshall rood en alle petten van Rocky groen.



 Doel: leren tellen tot 2.

Marshall helpt Kapitein Turbot uit de nood. Tel de pootjes en kleur het juiste aantal dingen.  
**'Ik ga vlammen!'**

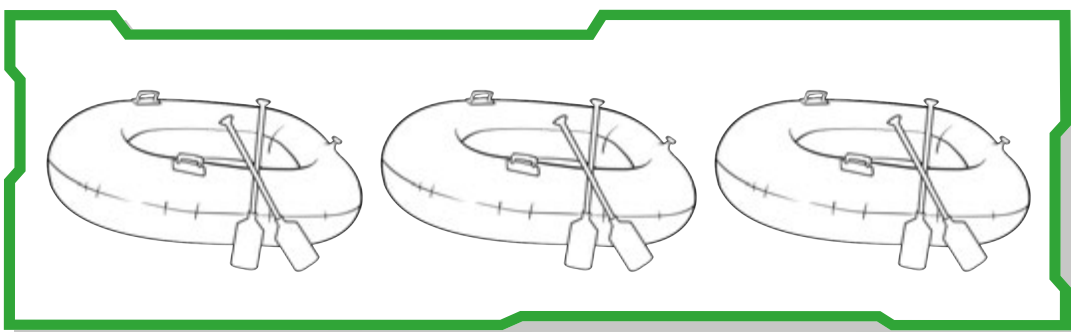
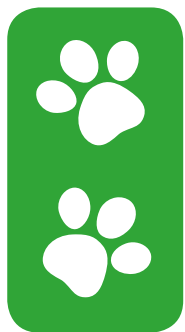
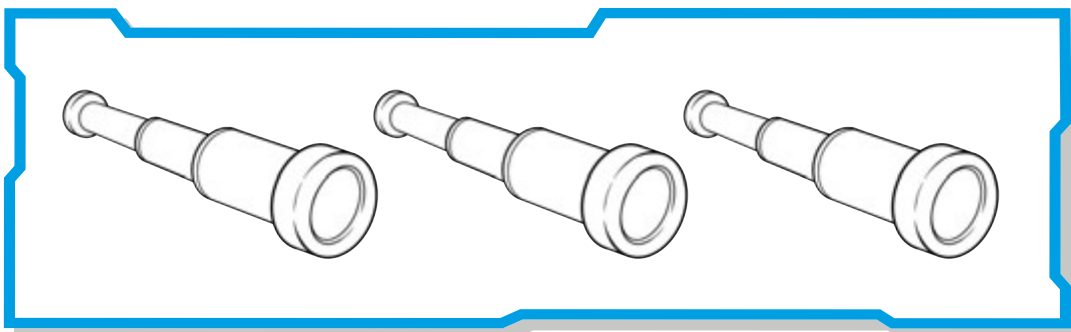
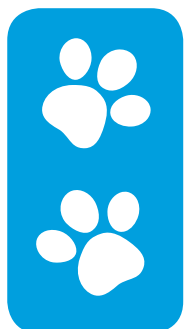
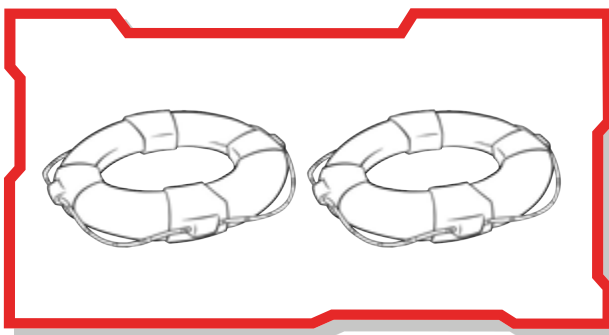

 Doel: leren tellen tot 2.

Door een grote storm is de boom veel appels verloren. Skye helpt de appels verzamelen in tonnen. Tel de appels en verbind ze met de juiste ton. **'Deze pup gaat vliegen!'**

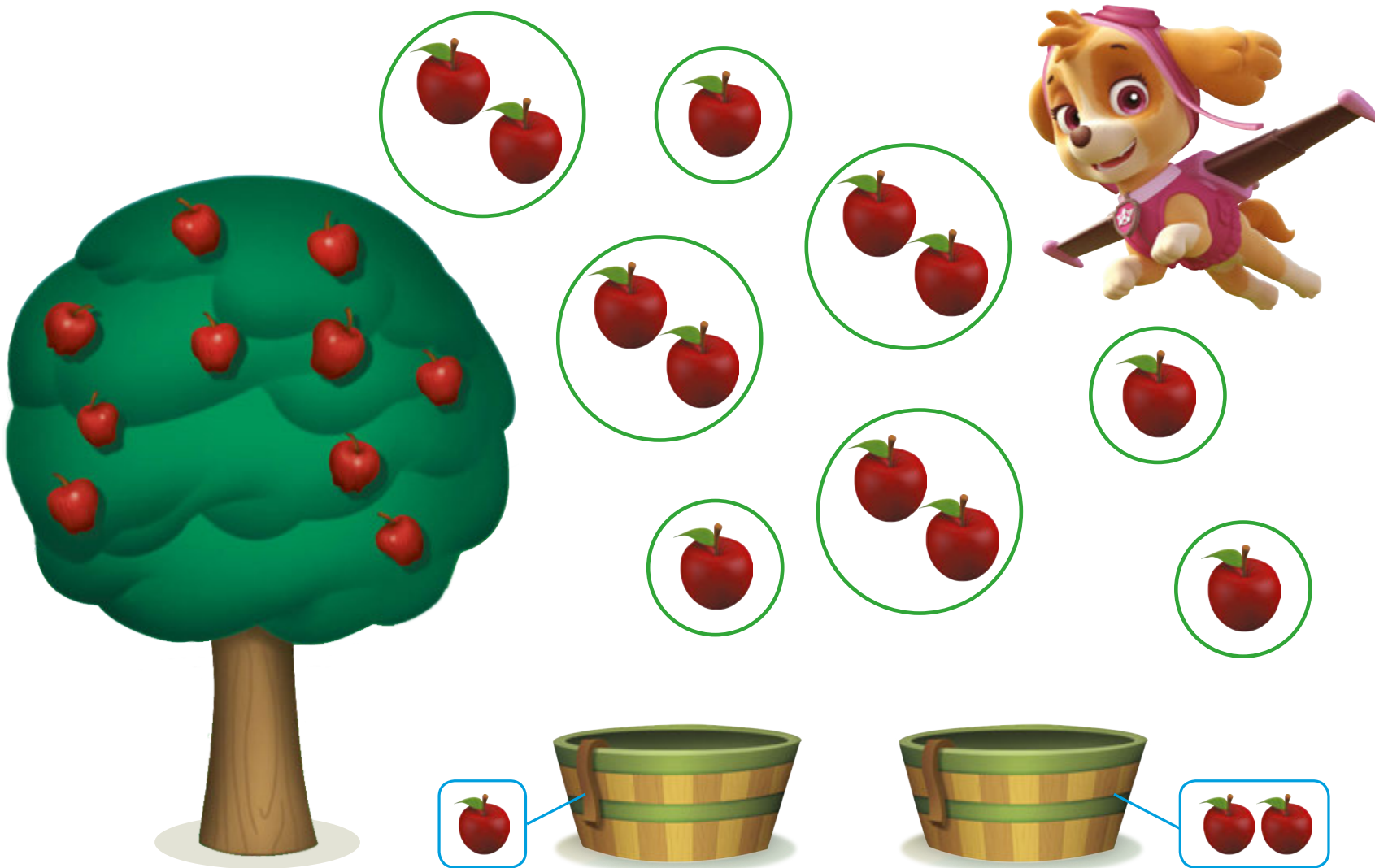

 Doel: leren tellen tot 2.